

OKTOPUS® PANEL-Jack GL-E

Crane and forklift attachment with integrated hydraulic functions for installing horizontal and vertical wall elements as well as installing short roof elements



2-circuit system

for construction site use according to DIN EN 13155

Use

The OKTOPUS® PANEL-Jack GL-E is a vacuum-based load handling device for laying sandwich panels in cold room construction and on industrial construction sites.

Hoist

- crane (e.g. truck-mounted crane, top slewing crane)
- forklift (in connection with a forklift adapter)

Suspension

- crane eye
- fork lift adapter

Material to be handled













The suction areas of the elements to be lifted must be air-impermeable, have to have an even and clean surface and must not be covered with protective foil.

Description

The OKTOPUS® PANEL-Jack GL-E is a vacuum-based load handling device with integrated hydraulic functions for the horizontal and vertical assembly of wall elements in industrial and refrigerated room construction up to a length of approx. 8 m.

The OKTOPUS® PANEL-Jack GL-E can be used with the proven Wirth circular and longitudinal vacuum cleaners to transport and assemble almost all commercially available sandwich elements and many trapezoidal sheet metal profiles.

The electrically operated vacuum pumps are supplied with energy by a 24 V DC battery system. Optical and acoustic signalling devices inform about deviations from the target state. Even in the event of a total power failure, the vacuum in each suction cup is maintained for at least 5 minutes. This ensures that the load is set down safely at all times.

	Crane attachment
	Forklift attachment
	Vertical wall installation
	Horizontal wall installation
	Roof installation
	Rotation 360°
	Tilt around horizontal axis
	Tilt around vertical axis (swivel)
	Side stroke
	Control panel at the device / cable remote control
	Radio remote control
	Battery



OKTOPUS® PANEL-Jack GL-E

Application data	
Working Load Limit	8 round suction pads (Ø 250 mm) 250 kg 12 round suction pads (Ø 250 mm) 400 kg 8 oval suction pads (100 mm x 320 mm) 130 kg 12 oval suction pads (100 mm x 320 mm) 200 kg 16 oval suction pads (100 mm x 320 mm) 260 kg
Weight crane attachment	approx. 230 kg
Weight forklift attachment	approx. 400 kg
Suction pads	round suction pads (Ø 250 mm) or oval suction pads (100 mm x 320 mm)
Vacuum generation	electric vacuum pump
Operation crane attachment	control panel at the device
Operation forklift attachment	Control panel connected to the device via cable, optional radio remote control
Vacuum system	dual-circuit vacuum system for construction site use
Nominal pressure pneumatic system	-0,65 bar bis -0,9 bar
Power supply	battery, 24 V
Optional equipment	- forklift adapter with integrated side stroke - radio remote control with
Optional facilities	- safety belts - protective caps
Movements	Rotating: manually 360°, all 45° lockable Slewing: hydraulically 0-90°, stepless Side stroke: in forklift operation 200 mm

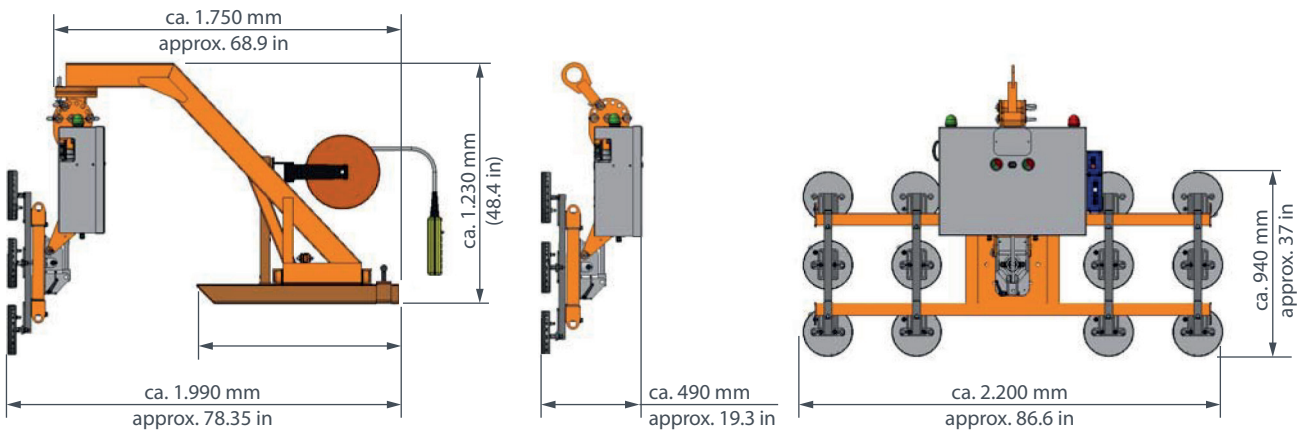

Subject to change in the interest of technical progress.

DB12_10 Ausg.: 05/19

Headquarter

Wirth GmbH
Brehnaer Straße 1
D-06188 Landsberg
Phone: +49 (0) 34 602 / 70 88 - 0
Fax: +49 (0) 34 602 / 70 88 - 111

Branch Office South

Wirth GmbH
Nelkenstraße 11
D-88074 Meckenbeuren
Phone: +49 (0) 75 42 / 94 29 - 44
Fax: +49 (0) 75 42 / 94 29 - 46

E-Mail:

oktopus@wirth-gmbh.com
info@wirth-gmbh.com

www.wirth-gmbh.com

